

**Product specification**

The PepperCorer processes bell peppers with a minimum length of 70 and a maximum length of 145 mm. The diameter that can be processed lies between 60 and 115 mm. The machine is therefore suitable for all bell pepper classes.

**Options**

- Conveyor belt
- Coring drill with a Ø of 30, 40, 45 and 50 mm
- Knives to cut into 2, 4, 6, 8, 12, 16, 20 or 24 pieces (cut vertically)
- Knives to cut into blocks of 1 or 2 pieces (cut horizontally)

**Technical data**

Type	PC-55
Connection voltage	400 V, 3 ph, 50/60 Hz
Installed voltage	5.65 kW
Dimensions (L x W x H)	3,300 x 1,300 x 2,590 mm
Compressed air	6 bar

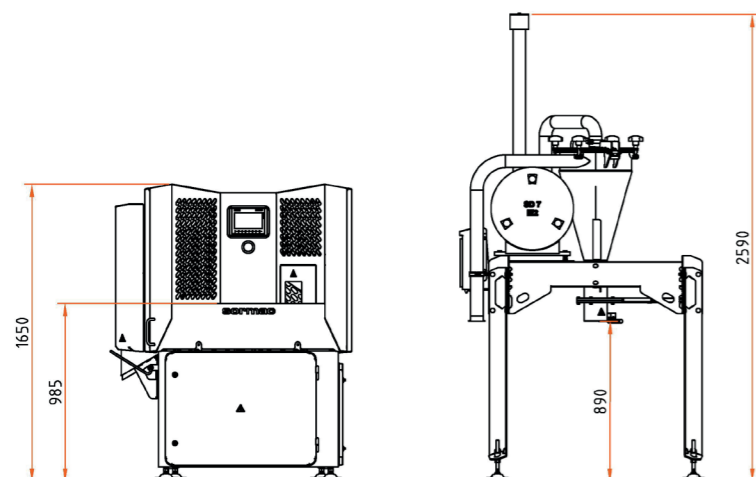
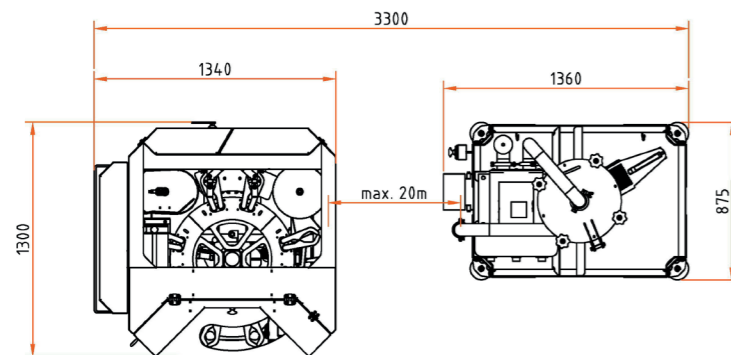

**PepperCorer PC-55**



**Operating principle**

Bell peppers are manually positioned in the clamping arms of the stock table in pairs from an optional conveyor belt. The clamping arms are pneumatically controlled and hold the product centred in position. The stock table rotates step-by-step. During a complete rotation, the peppers may go through a maximum of 4 process stations depending on the model of the machine.

In the first process, the pepper's stalk will be removed. In the second station, the pepper is cored and all the core seeds are removed by means of a vacuum unit. The corer is connected through a hose to the vacuum unit.

The next station is optional and consists of capping and cutting the bell pepper horizontally. The knives cut off the top and bottom at a pre-set distance. An extra knife can also be positioned that cuts the bell pepper in half. These functions can also be switched off.

The fourth and final station (option) introduces the segmenting section where the product can be processed into segments of various numbers of cuts. This function can also be switched off.

**Capacity**

The PepperCorer has a capacity of 3,100 pieces per hour depending on how skilled the operator is.



## Very many processing options

- **Kebab cubes** measuring 25 and 30 mm
- **Rings** up to 2 pieces
- **Segments** 2 to 24 pieces

## Suitable for all bell pepper classes

- Length that can be processed: 70 -145 mm
- Diameter that can be processed: 60 - 115 mm
- Coring drills: Ø of 30, 40, 45 and 50 mm

## High per operator capacity

Depending on the skill: 3,100 pieces per hour.

## Flexible

The PepperCorer measures the length of the bell pepper and adjusts the drilling depth to this. Without cutting into the walls, every bell pepper is perfectly cored.

## Digital control panel

- The capacity can easily be set digitally
- The software has various permission levels
- Product counter

## Pneumatic holders

The holders are driven pneumatically using compressed air. This means that the product is kept centred in its position.

## Hygienic

All seeds and membranes are collected in a crate. It can be placed in a different room to guarantee a hygienic working environment.



## Effective waste separation

The updated vacuum unit can be positioned at a distance of up to a maximum of 20 metres from the PepperCorer.

## Conveyor belt (optional)

- Supply the product from an ergonomic height
- Automatic start and stop



■ **Shashlik cubes**  
measuring 25 and 30 mm



■ **Rings**  
up to 2 pieces



■ **Segments**  
2 to 24 pieces