

Capacity

The Knife peeler MS range has an input capacity up to 5,850 lbs/hr, depending on product type and required waste percentage.

Options

- control panel with frequency controllers and digital control, including mounting and cabling
- waste transport system

Product specification

The Knife peeler MS range is suitable for pre-cleaned or pre-peeled root vegetables such as potatoes, beetroot and celery root. The produce diameter should be between 1 3/16" and 7 1/16" and the vegetables must be free of stones.

Technical data

Type	MS-10	MS-20	MS-30
Voltage	230/400 V, 50/60 Hz	230/400 V, 50/60 Hz	230/400 V, 50/60 Hz
Installed power	3.19 hp	3.45 hp	9.05 hp
Dimension (LxWxH)	90" x 55" x 93"	128" x 55" x 93"	166" x 57" x 101"
Water consumption	0 - 320 gal/h	0 - 530 gal/h	0 - 740 gal/h
Drum length (LT)	39 3/8"	79 3/4"	118 1/8"

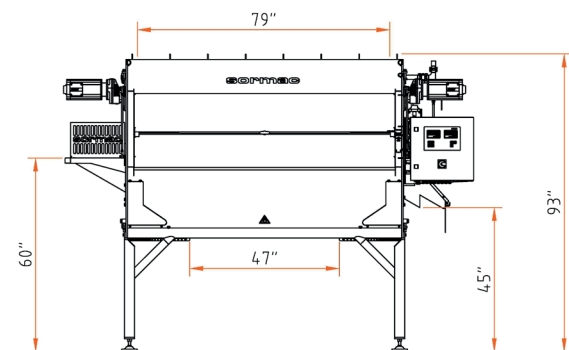
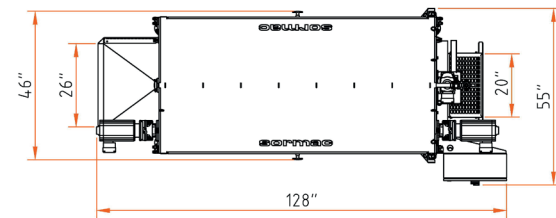

Dimensional sketch based on the MS-20 version

Patent EP 1 466 026 / other patents pending

Sormac Inc.
6800 Wales Rd.
Northwood, OH 43619
Office: +1 (567) 200-8420
info@sormac-inc.com
www.sormac.com

© Sormac B.V. All rights reserved. Subject to change.

MS-US2026/2

Knife peeler MS range



Operating principle

The Sormac Knife peeler MS range is suitable for continuous peeling of pre-washed or pre-peeled root products, like potatoes, red beets and celery roots.

The produce to be peeled is conveyed by a transport auger through a horizontal, rotating drum. The inside of this drum is equipped with a large number of knives. The dwell time and peeling effect can be controlled by varying the RPM of the drum and the speed of the transport auger. The special shape of the drum and the way the knives are positioned effectively avoids the produce from being flat peeled. The peeling waste is separated from the peeled product immediately and ejected by the rotating drum. The waste can be collected for removal in a crate or waste transporter via the waste funnel at the base of the machine.

In the model MS-20/Combi and MS-30/Combi, potatoes which have not been pre-peeled can be peeled as normal. The Combi-drum has several pre-peeling plates which replicate the effect of pre-peeling. The final peeling quality is equal in every respect to the MS-20 and MS-30 knife peeler.

Machine features

The machine consists of a stable housing in a frame, the peeling drum and a transport auger. In line with the patented Sormac system, the drum is suspended on both sides in 3 V-belts, and is driven by just 2 motors. The spray nozzles on the outer circumference of the transport auger allow wet peeling if required. There is a large cleaning hatch on two sides of the drum, so the inside of the drum and the conveying auger can be inspected and cleaned easily. The efficient drive and peeling methods means the energy consumption is very low.



The difference is in the details...

Certified plastic

Drum designed in blue plastic, meets the latest European directives (EU 10/2011).

High-quality peeling knives

Peeling knife life more than 2,000 operating hours.

Motor drive

- only 3 motors for the entire peeler
- hermetically sealed and splash proof (IP66)
- no unnecessary air movement above product

Hygienic design

Large detachable hatches allow quick access to the drum for cleaning or service. Drum hatch can be opened in one maneuver.

Effective avoidance of flat peeling

The patented design of the drum helps to effectively avoid flat peeling.

Higher yields

Less waste than flat bed peelers.

Low energy consumption

Low energy consumption due to efficient drive, with minimal friction.

Digital operating panel (optional)

The control panel is provided with frequency controllers for drum and auger. The operating panel can be used for digital adjustment of the RPM of the drum and the dwell time of the product.

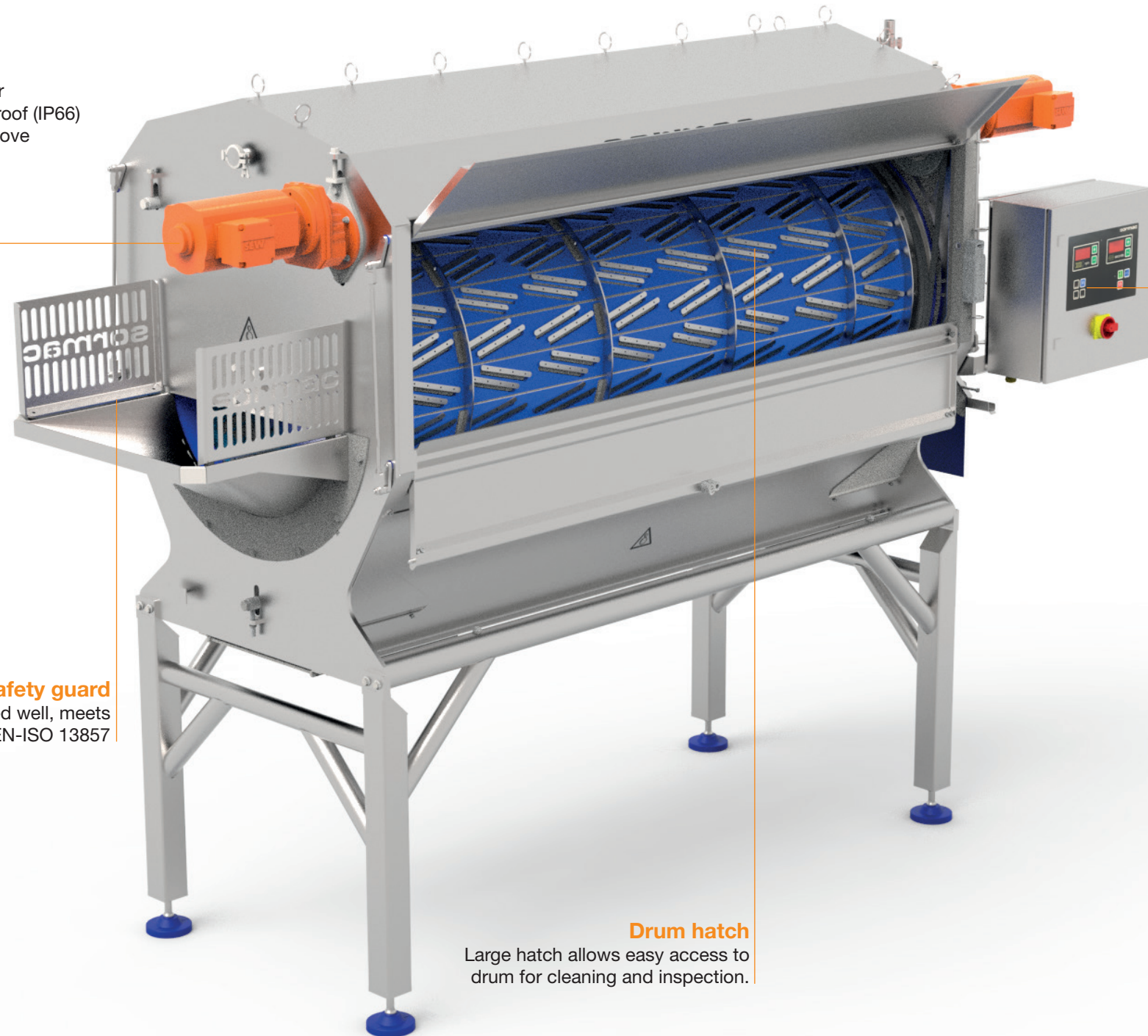
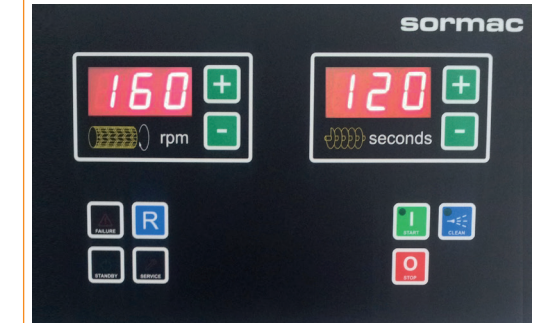

Safety guard
All moving parts are guarded well, meets NEN-EN-ISO 13857

Drum hatch
Large hatch allows easy access to drum for cleaning and inspection.

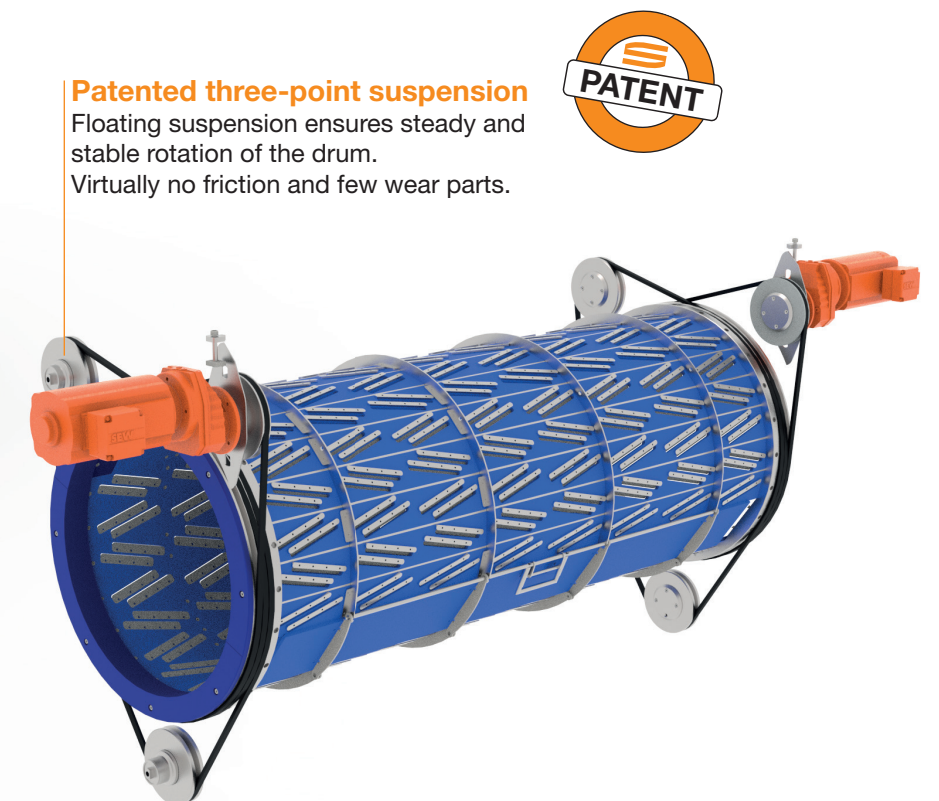

Patented three-point suspension
Floating suspension ensures steady and stable rotation of the drum. Virtually no friction and few wear parts.

