

Product specification

The Lettuce washer PULSTAR range washes all kind of leafy vegetables that float in water.

Options

- second flycatcher
- automatic filling and draining
- waterfall
- hinged fan
- air pipes with CIP
- cooling spiral in collection tank
- outfeed conveyor or dewatering conveyor
- UV-C unit
- dosing unit

Technical data

Type	PULSTAR-70	PULSTAR-100C	PULSTAR-100*
Voltage	400V, 3ph, 50/60Hz	400V, 3ph, 50/60Hz	400V, 3ph, 50/60Hz
Installed power	7.34 kW	7.34 kW	7.34 kW
Dimension (LxWxH)	5,250 x 2,400 x 2,500 mm	4,500 x 2,550 x 2,500 mm	6,250 x 2,550 x 2,500 mm
Volume	1,345 liter	1,450 liter	2,385 liter
Capacity**			
Iceberg lettuce	1,750 kg/h	1,500 kg/h	2,750 kg/h
Spinach	1,000 kg/h	750 kg/h	1,500 kg/h
Lamb's lettuce	1,000 kg/h	750 kg/h	1,500 kg/h
Baby leaf	750 kg/h	500 kg/h	1,250 kg/h

* PULSTAR-150 is available on request.

** The capacities depend on the desired dwell time.

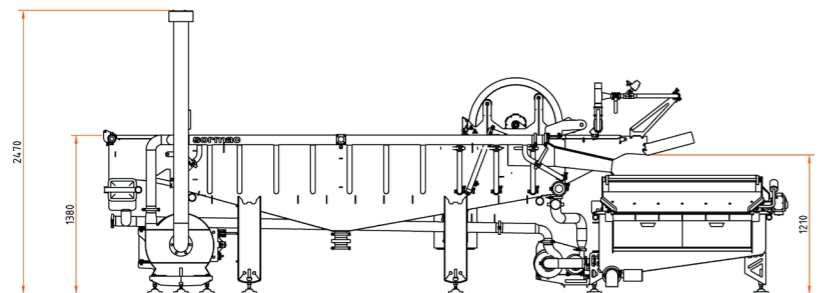
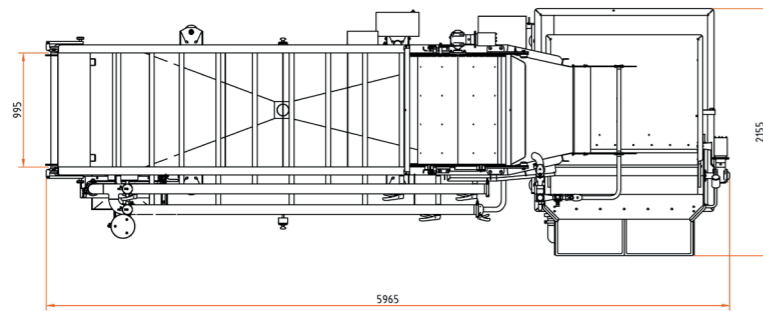

Dimensional sketch based on the PULSTAR-100

Lettuce washer PULSTAR range

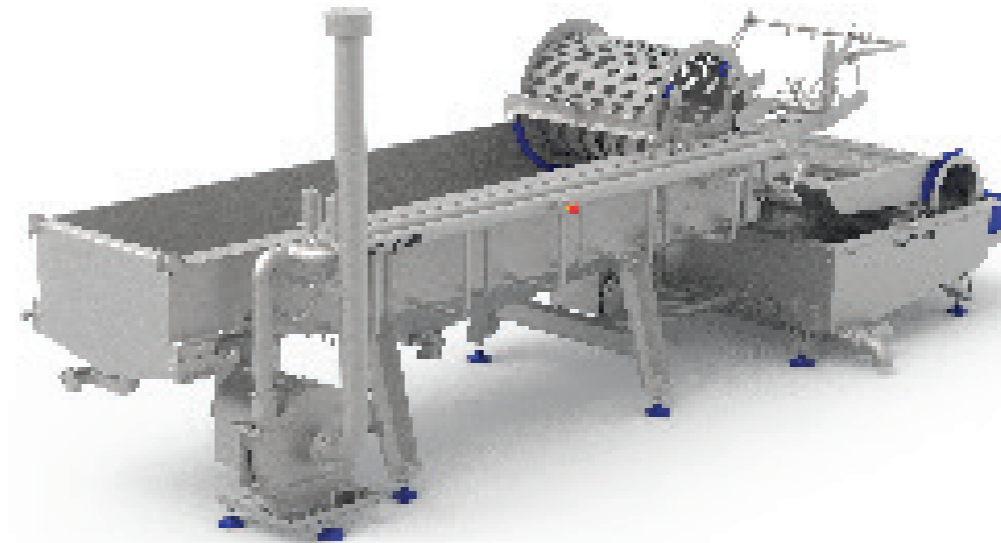

Operating principle

The Lettuce washer PULSTAR range has an integrated air injection system, enabling thorough cleaning without damaging the product. The quantity of air can be continuously adjusted, so that a stronger or gentler turbulence in the washing water can be achieved. The air injection system is divided into two sections, which operate alternatively. This alternating operation of the sections creates a peristaltic movement of the product through the washer.

The variable water flow of the frequency driven circulation pump in combination with the air injection switch/change frequency ensures that the product is transported through the washer and that the dwell time in the washer can be controlled accurately.

Water and product can be separated on an outfeed conveyor (optional) on the outfeed side. The water is passed through an overflow tank and then flows to the pump tank. Loose particles are filtered out of the water using a static sieve. The outfeed conveyor can optionally be configured as a dewatering conveyor. This has one or more beaters and vacuum stations.



Water bypass

Two separate frequency-controlled pumps transport the water to the intake and outfeed sides of the washer. This enables the dwell time of the product in the washer to be controlled accurately.

Peristaltic system

The specially developed air injection system creates a peristaltic movement of the product through the washer. The product is also pulled under water with minimum risk of damage and the dwell time in the washer can be regulated better (max. 2 minutes of dwell time).

Hygienic design

The washer design is such that all surfaces and pipes can be cleaned. The pipes have tri-clamp valves that are easy to open. A CIP (Cleaning in Place) configuration is possible as an option.



Outfeed conveyor (optional)

The outfeed conveyor transports the product out of the washer. The conveyor has a spray pipe for final cleaning of the product with clean water. There is a drip tray under the belt to guide all excess water into the pump tank. The conveyor features a quick-release system. There is an air knife at the end of the belt.

Flycatcher

To remove insects and other small floating particles.

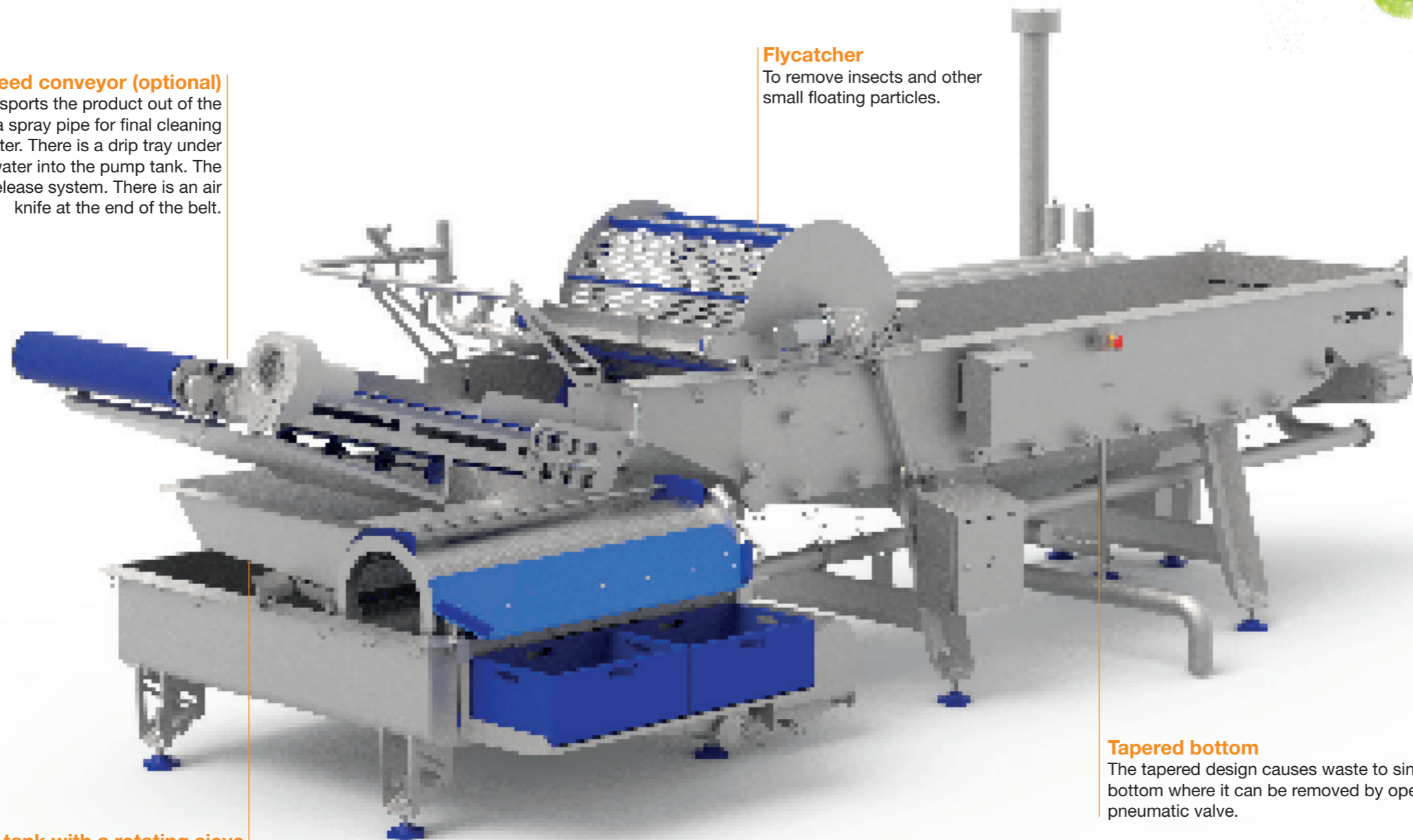

Collection tank with a rotating sieve

Loose particles are filtered out of the water in the collection tank. The scraper removes this waste and it is then deposited in boxes. The filtered water is pumped back into the washer.

Tapered bottom

The tapered design causes waste to sink to the bottom where it can be removed by opening a pneumatic valve.